

SCHEMATIC

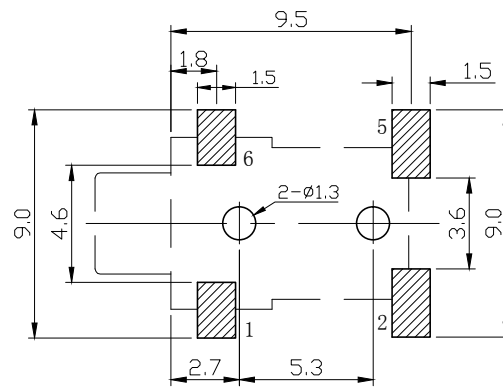
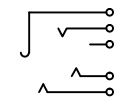

P.C.B. LAYOUT
TOP VIEW

SPECIFICATION

1. Rating : DC 30V 0.5A;
2. Contact resistance: $\leq 0.03 \Omega$;
3. Insulation resistance: $\geq 100M \Omega$ (DC250V);
4. Withstand voltage: 500VAC ;
5. Insertion and extraction force: 3-20N;
6. life test: 5,000 cycles.

6	HOUSING	1	PA9T	
5	CONTACT FOOT	1	SUS301	Ag-Plating
4	SPRING PIECE	1	BRONZE	Ag-Plating
3	CONTACT FOOT	1	BRASS	Ag-Plating
2	SPRING PIECE	1	BRONZE	Ag-Plating
1	CONTACT FOOT	1	SUS301	Ag-Plating
NO.	DESCRIPTION	QTY	MATERIAL	PLATING



Title		2.5mm Earphone Jack SMT 90° With Post				
Tolerances	<i>Drawer</i>	<i>Naomi</i>	Part No:			
	<i>Checked</i>	<i>Summer</i>	WCT-EPJ-S2027-2			
X ±0.15 .X ±0.05	<i>Approved</i>	<i>Macus</i>	Cus. Part No:			
	<i>Date</i>	2017.06.09	WCT-EPJ-S2027-2			
Angles	<i>Projection</i>	<i>Version</i>	<i>Size</i>	A4	<i>Units</i>	mm
± 3°		A	<i>Scale</i>	1:1	<i>Sheet</i>	1/2

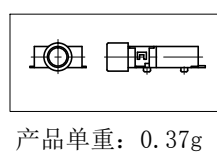
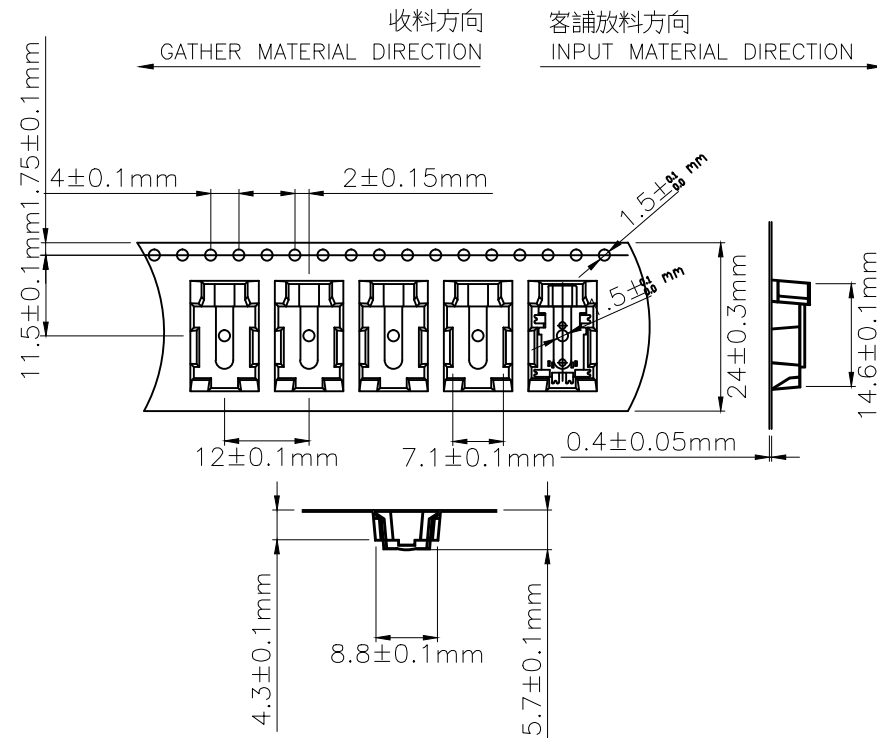
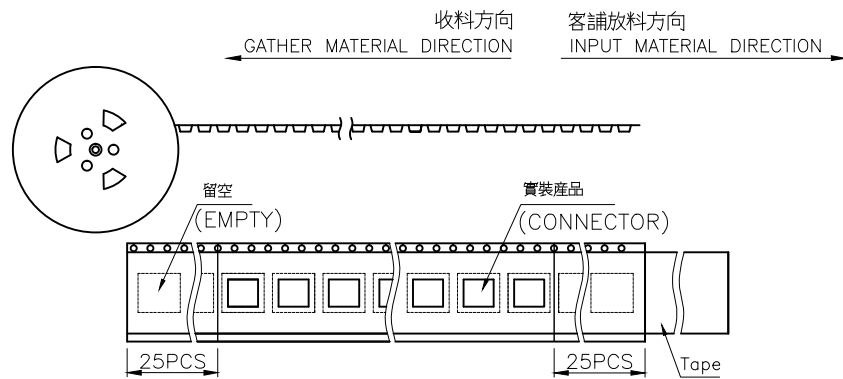

产品单重: 0.37g

载带(1000pcs/盘)

DIMENSIONS:
33.5*6.5*34.5
BOX

每两卷产品包一个内箱

DIMENSIONS:
35*35*37
BOX

5内箱装一外箱

1. 每PCS产品单重为0.37g
2. 载带使用13*24m/m胶盘, 包装数量:1000PCS. (单重:395g)
3. 内箱规格:33.5*6.5*34.5cm. (单重:98.7g)
4. 外箱规格:35*35*37cm. (单重:666g)
5. 整箱毛重 9.47Kg 单重: 3.7Kg

PACKAGE INFORMATION

PART NUMBER	Q'TY PER REEL	REEL PER BOX	Q'TY PER BOX
WCT-EPJ-S2027-2	1000PCS	10 R	10000 PCS



Title	2.5mm Earphone Jack SMT 90° With Post					
Tolerances	Drawer	Naomi	Part No:			
	Checked	Summer	WCT-EPJ-S2027-2			
X ±0.15 .X ±0.05	Approved	Macus	Cus. Part No:			
	Date	2017.06.09	WCT-EPJ-S2027-2			
Angles	Projection	Version	Size	A4	Units	mm
± 3°		A	Scale	1:1	Sheet	2/2