



NOTES:

MATERIAL SPECIFICATION:

1. HOUSING MATERIAL: SEE PART NO.
2. SHELL MATERIAL: SEE PART NO. T:0.30mm
PLATING: SEE PART NO.
3. BACK COVER MATERIAL: SPCC T:0.30mm
PLATING: NICKEL
4. SHRAPNEL MATERIAL: SEE PART NO. T:0.30mm
PLATING: SEE PART NO.
5. TERMINAL: COPPER ALLOY T:0.25mm
PLATING: SEE PART NO.

ELECTRICAL CHARACTERISTIC:

1. VOLTAGE CURRENT RATING: 1AMP, 30V DC;
2. INSULATION RESISTANCE: 1000MΩMIN;
3. CONTACT RESISTANCE: 30mΩMAX;
4. WITHSTANDING VOLTAGE: 500V AC;

MECHANICAL:

1. MATING FORCE: 3.57 KG MAX
2. UNMATING FORCE: 1.02 KG MIN.

Part No: WCT-USB2-01 D F2 08 1 C1 X X S 3 E
 1 2 3 4 5 6 7 8 9 10 11

1. Products Distination : USB2=USB 2.0
2. Type Difference : D=Double Layer
3. Specifications Distination : F2=Female To Board
4. Pin : 08=08Pin
5. Housing Material : 1=PBT
6. Special Practice : C1=外扣式無彈
7. Shell Material : P=SPCC 2=C2680
8. Housing Color : 1=White 3=Black
9. Contact Plating : S=Gold Flash
10. Package : 3=Tray
11. Environmental : E=RoHS(Bright)



Title	Dual USB 2.0 A TYPE 4P Female DIP 90° With Shell Foot Kink					
Tolerances	Drawer	Naomi	Part No:			
Linear	Checked	Summer	WCT-USB2-01DF2081C1XXS3E			
X ±0.15	Approved	Macus	Cus. Part No:			
.X ±0.05	Date	2017.07.06	WCT-USB2-01DF2081C1XXS3E			
Angles	Projection	Version	Size	A4	Units	mm
± 3°		A	Scale	1:1	Sheet	1/2

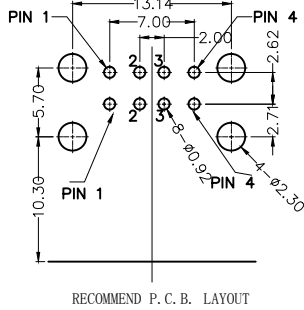
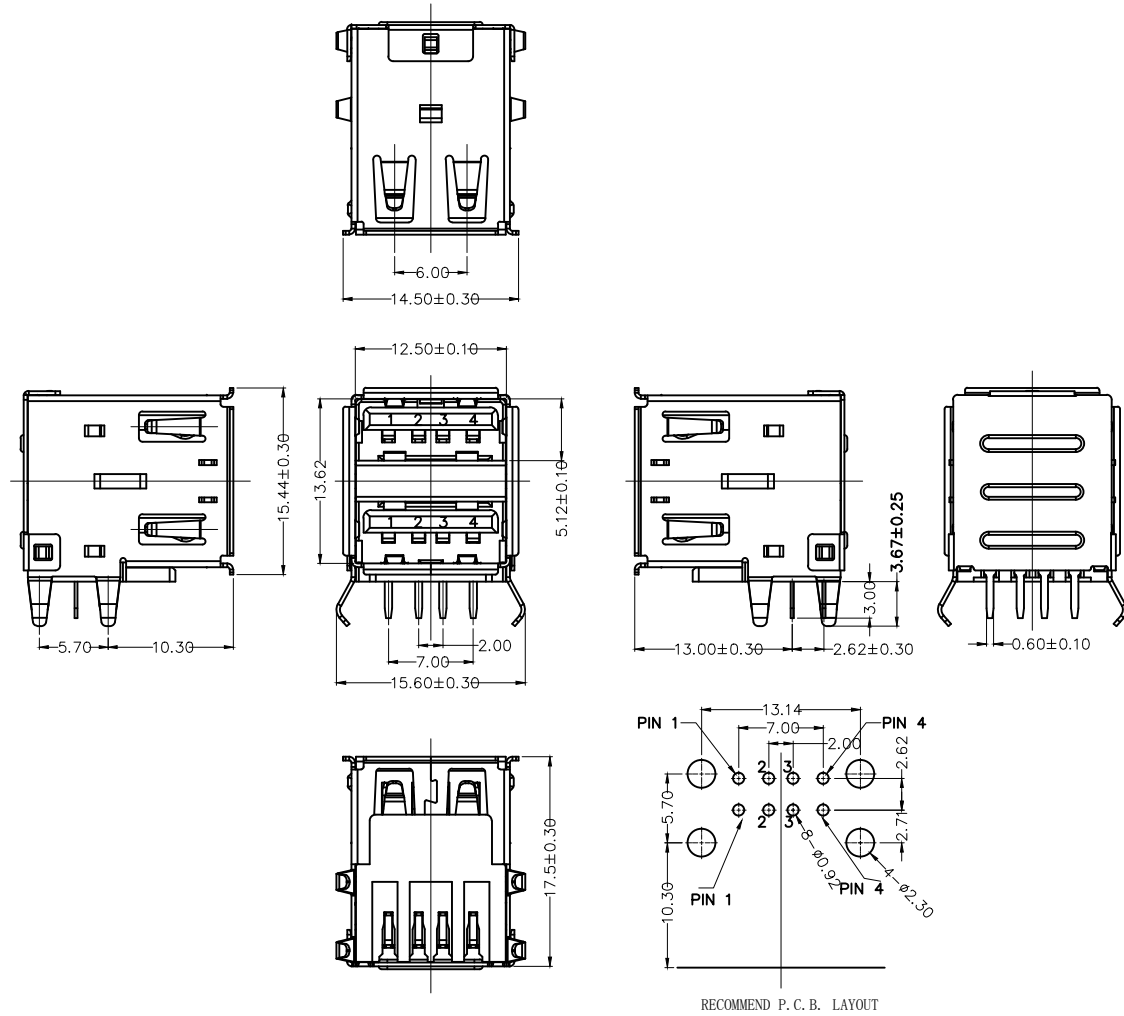

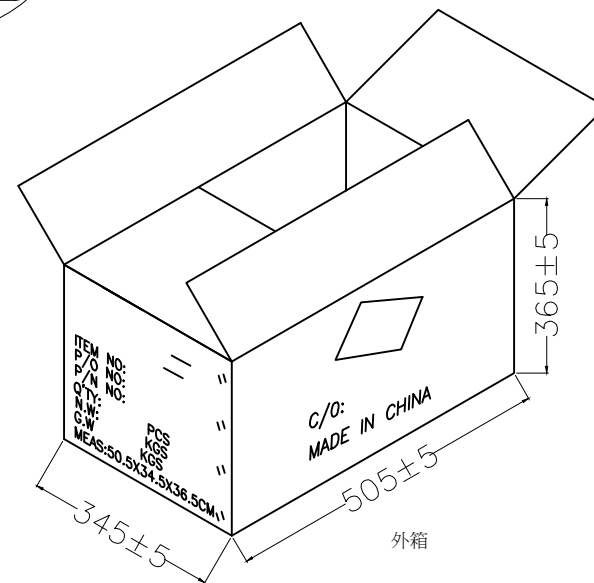
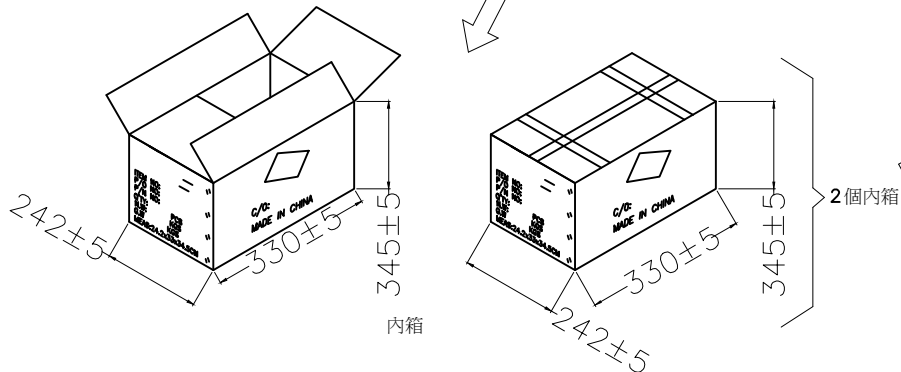
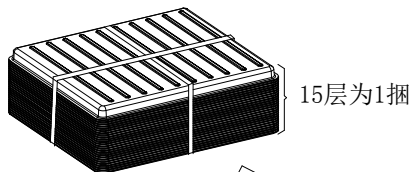
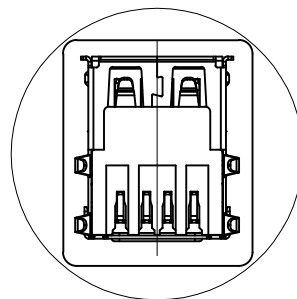
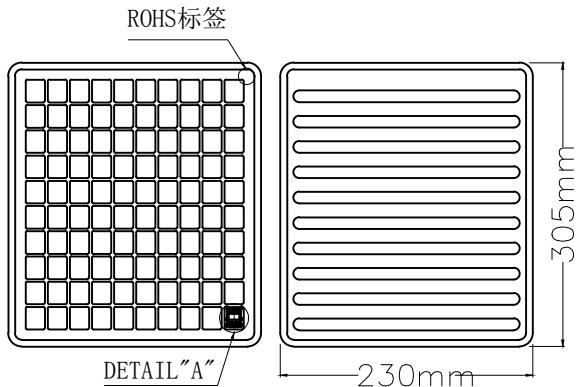
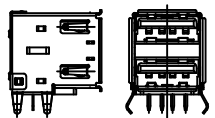

包装说明:

1. 把检验好之成品如图示方向放入真空盘, Pin针脚向上摆放, 每盒放100PCS产品, 然后盖好上盖, 四周如图示用装订针订好
2. 把订好的真空盘如图示15盘为一捆, 共计1500PCS产品, 然后用PE膜缠好包装放入内箱。
3. 把装好产品的2个内箱并排放入外箱中, 然后在外箱相应位置处贴上标签, 共计产品3000pcs.
4. 注意纸箱内不可有混装, 多装及短装现象。
5. 规格尺寸: 真空盒: 305*230MM
内箱: 242*330*345MM
外箱: 505*345*365MM



Title		Dual USB 2.0 A TYPE 4P Female DIP 90° With Shell Foot Kink				
Tolerances	Drawer	Naomi	Part No:			
Linear	Checked	Summer	WCT-USB2-01DF2081C1XXS3E			
X ±0.15	Approved	Macus	Cus. Part No:			
.X ±0.05	Date	2017.07.06	WCT-USB2-01DF2081C1XXS3E			
Angles	Projection	Version	Size	A4	Units	mm
± 3°		A	Scale	1:1	Sheet	2/2